

WMF SERIES WALL MOUNTED CABINET

ASSEMBLY INSTRUCTIONS

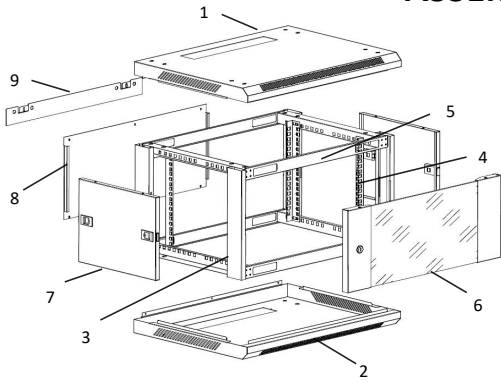

Component list:

1. Top cover	1pc	6. Front door	1pc
2. Bottom plate	1pc	7. Side doors	2pcs
3. Left & right frame	2pcs	8. Rear panel	1pc
4. Vertical rails	4pcs	9. Mounting bracket	1pc
5. Horizontal beams	4pcs		

Hardware list:

Assembly screws	
a. M6x12 pan head screws	24pcs
b. M3.5x6 pan head screws	40pcs
c. M6 cage nuts	8pcs
d. M6 flange nuts	16pcs

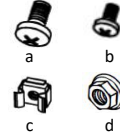

ASSEMBLY STEPS:

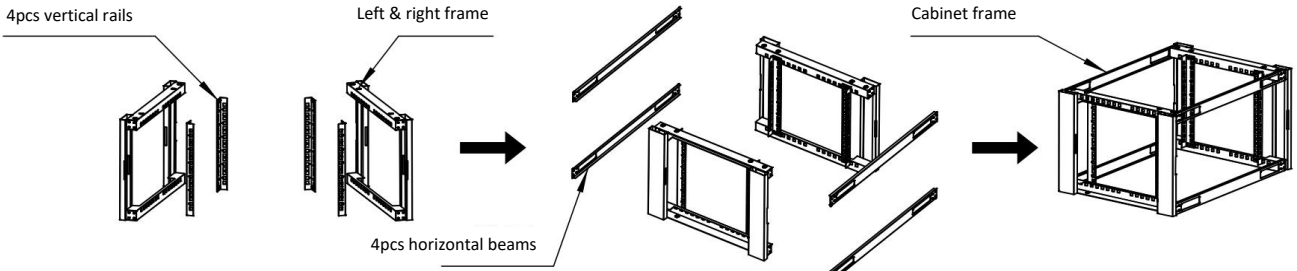

1. Use 8sets M6x12 pan head screws & cage nuts to fix 4pcs vertical rails on the left & right frame.



2. Connect 4pcs horizontal beams and the left & right frame by 32pcs M3.5x6 screws.

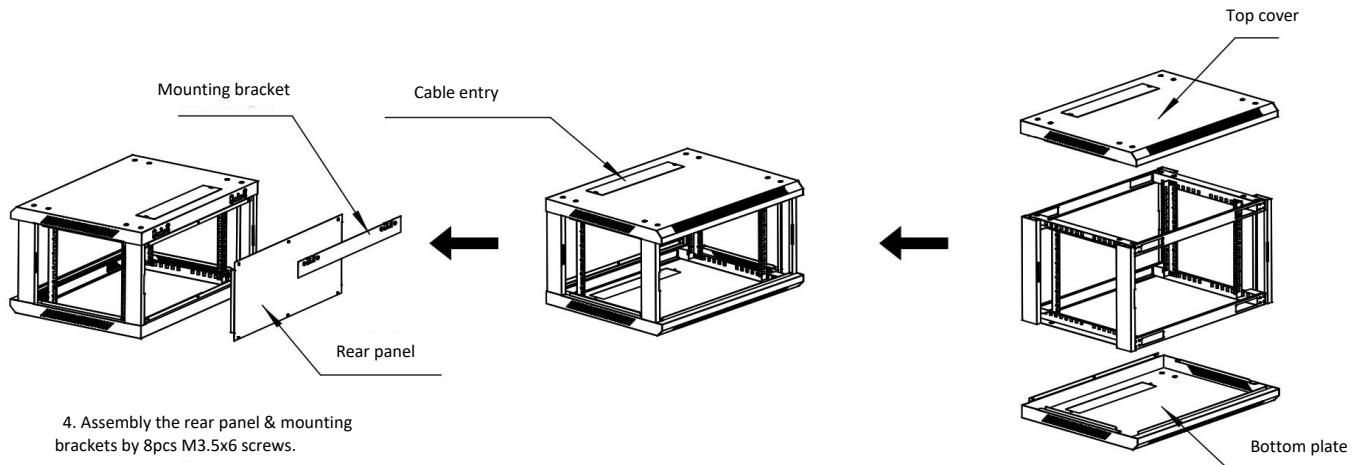

4. Assembly the rear panel & mounting brackets by 8pcs M3.5x6 screws.



3. Connect the top cover & bottom plate with the cabinet frame by 16sets M6x12 pan head screws and flange nuts.

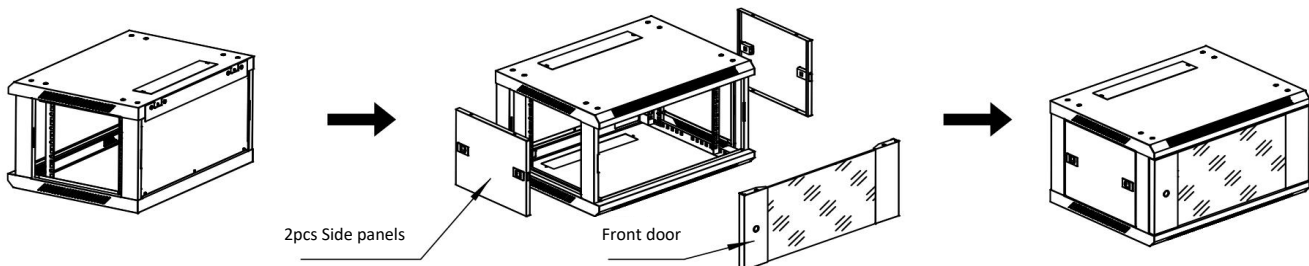

5. Install 2pcs side panels and the front door.

Finished

WMF SERIES WALL MOUNTED CABINET

Mounting method

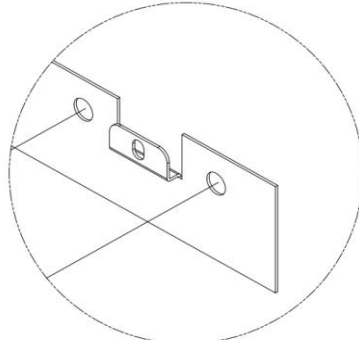
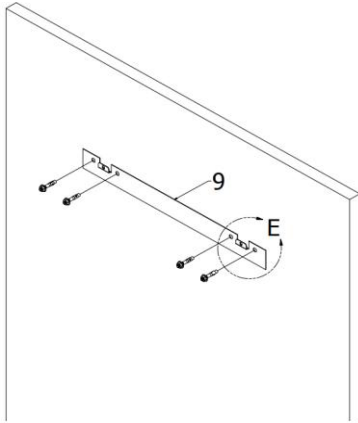

Detail E

Step 1:
Fix the mounting bracket on the wall by 4pcs anchor bolts.

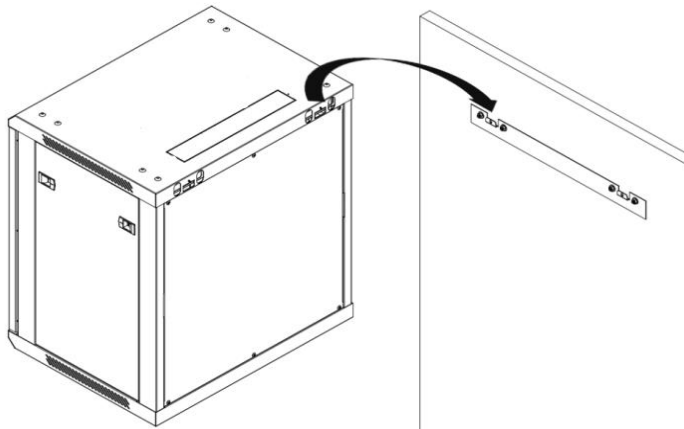

Step 2:
Hang the cabinet's 2 mounting notches onto the 2 mounting hooks on the plate attached to the wall.